

Description

The Bobcat® wood chipper attachment grinds branches, trees and limbs, reducing branch volume 10 to 1. Unlike a pull-type chipper, the wood chipper attachment can easily be placed into backyards and remote areas with the manoeuvrability of a Bobcat® loader. Hydraulic power feed is included as standard equipment. It allows the feed roller to move branches into the wood chipper at a consistent speed so the operator can work safely and efficiently.

Dimensions

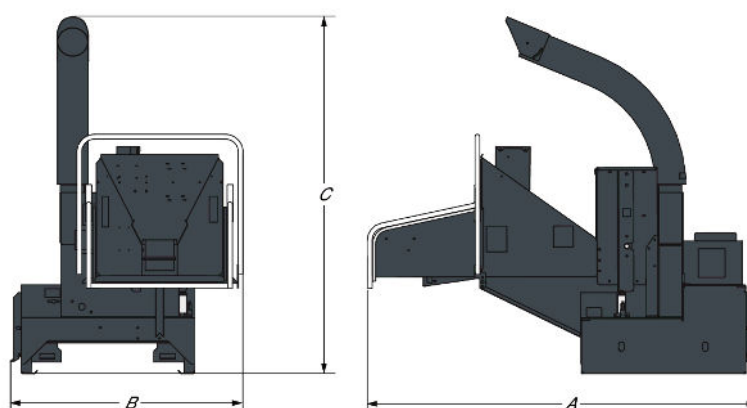

Description	Item number	Overall length (A) (mm)	Overall width (B) (mm)	Overall height (C) (mm)
Chipper 5A Non-CE	6719129	-	-	-
Chipper 8B	7117662	2594.0	1549.0	2369.0

Weights

Description	Item number	Operating weight (kg)	Shipping weight (kg)
Chipper 5A Non-CE	6719129	520.0	520.0
Chipper 8B	7117662	753.0	753.0

Characteristics and performance

Description	Item number	Feeder opening (mm)	Continuous chipping size (mm)	Feed table height (mm)	Blades	Flow range (l/min) (L/min)	Discharge chute
Chipper 5A Non-CE	6719129	125.0	75.0	600.0	4 reversible stool steel blades	64.0-98.0	Rotates 360°
Chipper 8B	7117662	235.0	127.0	645.0	4 reversible tool steel blades	98.0-151.0	Rotates 360°

Main features

- The Bobcat® Wood Chipper attachment is ideal for grinding branches, trees and limbs, reducing branch volume from 10 to 1
- You can grind branches and trees up to 13 cm in diameter
- The discharge chute can be rotated 360°, giving you maximum flexibility of use
- Operate the wood chipper from the cabin or using the Bobcat® Remote Attachment Control (RAC) system. This allows the operator to start or stop the loader's engine and chipper rotation when standing beside the attachment
- The unit comes with an automatic hydraulic feed, with speed control and a load sensing system for optimum performance and constant flow
- Large diameter, high-torque feed roller for increased efficiency and productivity
- Variable speed feed drive for adjusting the feed rate with a reversible option in case of plugging
- For more work flexibility, dual mounting locations allow material to be fed from the front or right side of the loader

Applications

- Agriculture
- Forestry
- Landscaping
- Road work, Recycling and Cleaning

Loader Compatibility

Description	Item number	Compatible with loader	Functional requirements
Chipper 5A Non-CE	6719129	A770-B, T450E IIIB, T590E IIIB, T590B iT4, T650E iT4, T650B iT4, T770E IV, T770E T3, T770B T3, T870E IV, T870B T3, S450E IIIA, S450B T2, S510E IIIA, S510B, S530E IIIA, S530B, S550E IIIB, S550B iT4, S570B iT4, S590E IIIB, S590B iT4, S630E iT4, S630B iT4, S770E IV, S770E T3, S770B T3, S850E IV, S850E T3, S850B T3, A770E IV, S450 V, S510E V, S530E V, T590E V, T450E V, S66, S76, T66, T76, S510B, S530B, S550E V, S590E V, S630B iT4, S650B iT4	-
Chipper 8B	7117662	A770-B, T590E IIIB, T590B iT4, T650E iT4, T650B iT4, T770E IV, T770E T3, T770B T3, T870E IV, T870B T3, S530E IIIA, S530B, S550E IIIB, S550B iT4, S570B iT4, S590E IIIB, S590B iT4, S630E iT4, S630B iT4, S770E IV, S770E T3, S770B T3, S850E IV, S850E T3, S850B T3, A770E IV, S530E V, T590E V, S66, S76, T66, T76, S530B, S630B iT4, S650B iT4	-

BE OM **EN OFFERT**

Klicka bara på **knappen** eller skanna **QR-koden** nedan för åtkomst till vårt offertformulär.

Vi kontaktar dig så snart som möjligt. Tack!



BEGÄR OFFERT

